

ASSEMBLY INSTRUCTION

BIG DADDY RECLINING ADIRONDACK CHAIR WITH PULL OUT OTTOMAN

SKU #: LFW008-1 & LFW009-1 & LFW010-1

MADE IN CHINA

READ & SAVE THESE INSTRUCTIONS:

- Examine all packing material before assembling, shortages may occur from parts left in the packing material.
- To avoid damage & dirty, suggest the consumer to place the unit on a non-abrasive surface, such as carpet then go with assembling.
- Please follow below instructions to assemble step by step.

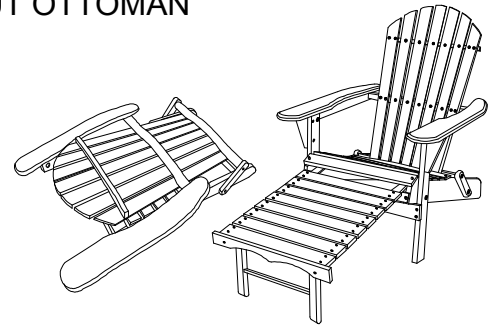

PARTS LIST

Parts No.	Parts List	Description	QTY	Parts No.	Parts List	Description	QTY
A		SEAT	1PC	1		BOLT Ø 1/4" * 1-3/4"	4PCS
B		BACK SUPPORT	1PC	2		BOLT Ø 1/4" * 2-1/4"	2PCS
C		RIGHT LEG	1PC	3		BOLT Ø 5/16" * 2-1/4"	4PCS
D		LEFT LEG	1PC	4		Washer Ø 1/4" * Ø 19 * 1mmH	8PCS
E		RIGHT ARM	1PC	5		Washer Ø 5/16" * Ø 23 * 1.5mmH	8PCS
F		LEFT ARM	1PC	6		PLASTIC WASHER Ø 35 * Ø 25 * 3 mm	4PCS
G		WOOD HINGE	2PCS	7		PLASTIC WASHER Ø 25 * Ø 9 * 2 mm	6PCS
H		WOOD SLAT	1PC	8		Nut Ø 1/4" * 11mm * 8mm	2PCS
I		OTTOMAN	1PC	9		Nut Ø 5/16" * 12.6mm * 8.5mmH	4PCS
J		WOOD SLAT	1PC	10		SCREW Ø 8 * 1-1/4"	2PCS
K		WOOD SLAT	1PC	11		SCREW Ø 8 * 1-1/2"	6PCS
				12		HEXAGONAL WRENCH Ø 1/4" & Ø 5/16"	2PCS
				13		Y WRENCH Ø 1/4" & Ø 5/16"	1PC
				14		PHILLIPS HEAD SCREWDRIVER IS REQUIRED (NOT INCLUDED)	

- 1 Attach right leg C and left leg D to the seat A, then insert bolt #3 with washers #5 , plastic washers #7 , nut #9 by hexagonal wrench #12 and Y wrench #13 to tighten, as shown in the diagram.

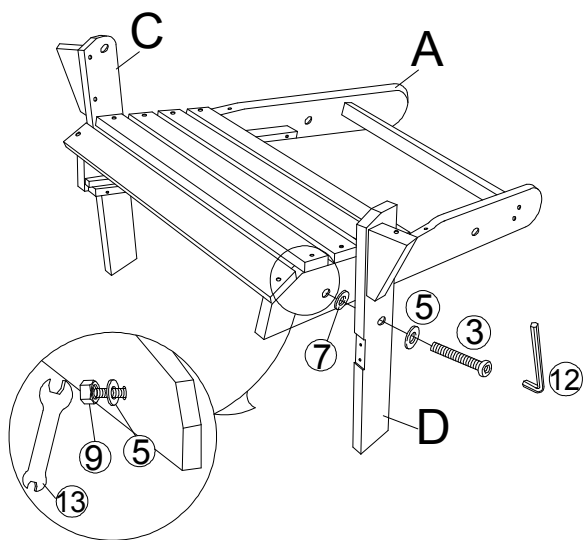

- 2 Attach wood slat H to right leg C and left leg D , insert the screws #11 by phillips head screwdriver #14 to tighten , as shown in the diagram.

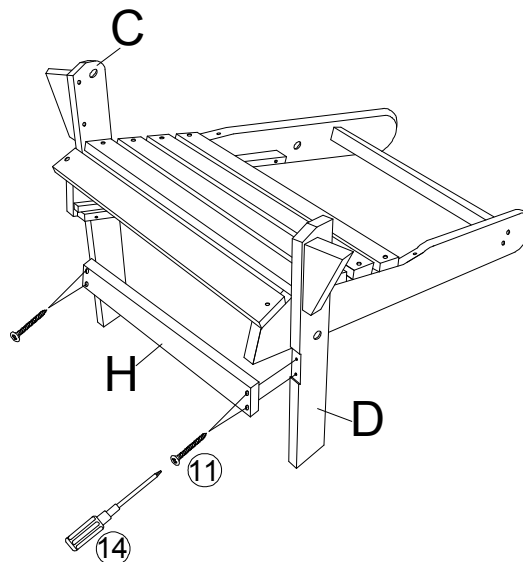

- 3 Insert the ottoman I underneath the seat A, as shown in the diagram.

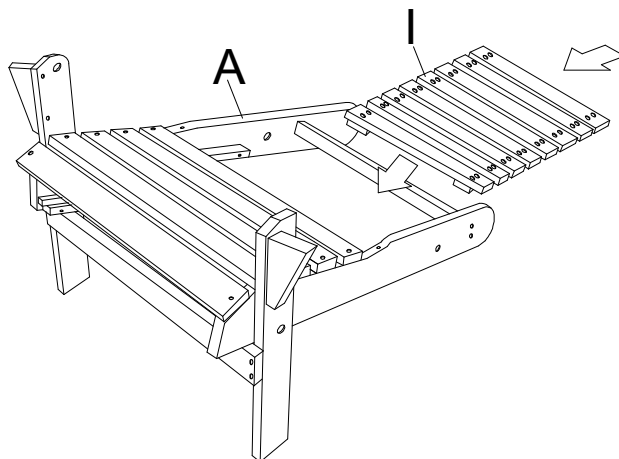

- ④ Attach wood slat J to the ottoman I, tighten screws #10 by phillips head screwdriver #14, as shown in the diagram.

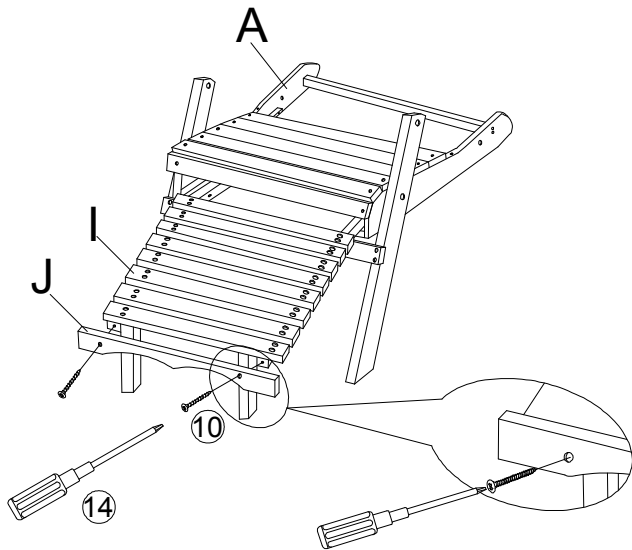

- ⑤ Attach wood slat K to the seat A, then insert screw #11 by phillips head screwdriver #14

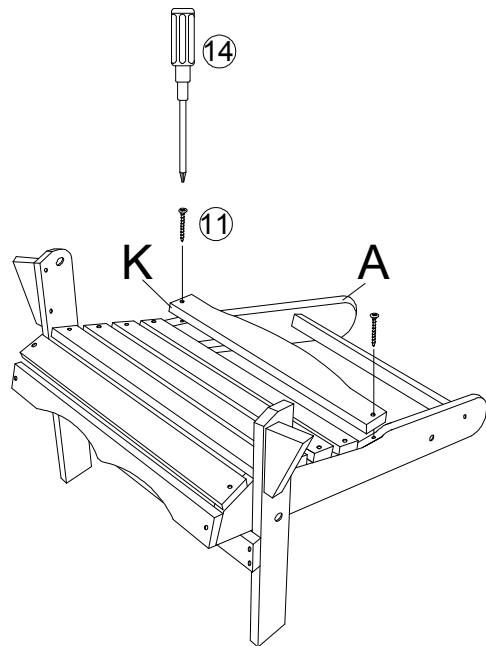

- ⑥ Attach the wood hinge G to the seat A, then insert the bolt #2 with washers #4 , plastic washers #7 , nut #8 by hexagonal wrench #12 & Y wrench #13, not completely tighten, as shown in the diagram.

